



# WILDLIFE MANAGEMENT & MITIGATION PLAN FOR TUMKUR BRANCH CANAL, UPPER BHADRA PROJECT



## KARNATAKA FOREST DEPARTMENT GOVERNMENT OF KARNATAKA



Environmental Health & Safety Consultants Pvt. Ltd.,  
#174/New No.13/2, 14th E Cross,  
Industrial Town, Agrahara Dasarahalli,  
Bangalore - 560 044, Karnataka



Office of the Executive Engineer,  
Visvesvaraya Jala Nigam Limited,  
UBP Division No. 9, Anjaneya Seva Samiti Building,  
Manangi Thanda, Manangi Post, N.H.04, Sira,  
Tumkuru District -572137, KA

March 2020

## ABBREVIATIONS

---

BPL	Below Poverty Line
CA	Compensatory Afforestation
CH	Chainage
ESZ	Eco-Sensitive Zone
GoI	Government of India
GoK	Government of Karnataka
KSNDMC	Karnataka State Natural Disaster Monitoring Centre
MoEF&CC	Ministry of Environment, Forest & Climate Change
NBWL	National Board for Wildlife
RF	Reserve Forest
SBWL	State Board for Wildlife
TBC	Tumkur Branch Canal
WLS	Wild Life Sanctuary

## TABLE OF CONTENTS

---

INTRODUCTION .....	1
1.1 Preamble .....	1
1.2 Need for the Project .....	1
1.3 Need for Wildlife Management Plan .....	2
TUMKUR BRANCH CANAL.....	1
2.1 TUMKUR BRANCH CANAL .....	1
FLORA IN BUKKAPATNA CHINKARA WLS .....	1
3.1 Flora in Bukkapatna Chinkara WLS .....	1
3.2 Demand & timber and non timber forest produce .....	2
FAUNA IN BUKKAPATNA CHINKARA WLS.....	3
4.1 Fauna in thorn and scrub forests of Tumkur Division.....	3
4.2 Fauna in Bukkapatna Chinkara WLS .....	3
4.2.1 Conservation status of mega-faunal species in Bukkapatna Chinkara WLS.....	4
ANTICIPATED IMPACTS.....	8
5.1 Habitat Fragmentation .....	8
5.2 Loss of Habitat.....	8
5.3 Disturbance during project implementation .....	8
5.4 Road kills/accidental fall into canal.....	9
WILDLIFE MANAGEMENT PLAN.....	10
6.1 Provision of wildlife crossings .....	10
6.1.1 Single Lane (over pass) bridges .....	12
6.1.2 Underpasses (culverts).....	12

6.3 Super passages .....	13
6.4 Foot bridges .....	13
6.2 Mitigation of impacts during project implementation phase .....	13
6.3 Provision for chain link mesh .....	14
6.4 Augmenting the factors of habitat .....	14
6.4.1 Creation of water holes .....	14
6.4.2 Plantation along canal banks and single lane (overpass) bridge .....	15
6.5 Provision of animal guides .....	17
6.6 Provision of ramps .....	17
6.7 Impact monitoring .....	17
6.8 Compensatory afforestation .....	18
COST ESTIMATE .....	20
REFERENCES .....	21

## TABLE OF FIGURES

---

Figure 1 Map showing the location and alignment of Tumkur Branch Canal in Bukkapatna Chinkara WLS.....	1
Figure 2: Typical view of culvert .....	12
Figure 3: Typical view of water holes.....	15
Figure 4: Typical design of water holes .....	15
Figure 5: Typical view of ramps.....	17

## **LIST OF TABLES**

---

Table 1 Forest land required for diversion to construct Tumkur Branch Canal, Bukkapatna WLS.....	2
Table 2: GPRS Coordinates of Forest land to be diverted for the construction of Tumkur Branch Canal in Bukkapatna Chinkara WLS.....	3
Table 3: IUCN conservation status, 2019 and Wildlife (Protection) Act, 1972 of the mega-faunal species recorded in Bukkapatna Chinkara WLS.....	4
Table 4: Conservation aspects of mega-faunal species recorded in Bukkapatna Chinkara WLS..	4
Table 5: Checklist of native tree species proposed for plantation alongside canals and throughout overpass bridges.....	16
Table 6 : Details of Forest land required and CA land provided to Karnataka Forest Department .....	18
Table 7: Additional Forest Land Required for construction of Tumkur Branch Canal.....	18
Table 8 : Compensatory Afforestation Land utilization.....	19
Table 9 : Cost estimate for implementation of Wildlife Management & mitigation Plan.....	20

## ANNEXURES

---

Annexure-I	Command area map of Upper Bhadra Project & Administrative approval accorded for the project
Annexure-II	Map showing alternative analysis of the proposed alignment of TBC in Bukkapatna Chinkara WLS
Annexure-III	SoI Toposheet showing the alignment of TBC in Bukkapatna Chinkara WLS and mitigation measures
Annexure-IV	Geo-referenced village maps showing the alignment of TBC in Bukkapatna Chinkara WLS
Annexure-V	Village maps showing TBC and mitigation measures
Annexure-VI	Compensatory Afforestation land suitability certificate, RTC mutation copy, SoI Toposheet and village map showing CA land.

## 1.1 Preamble

Upper Bhadra lift irrigation Scheme envisages lifting of 17.40 TMC of water in first stage from Tunga River to existing Bhadra reservoir and lifting of 29.90 TMC of water in second stage from Bhadra reservoir to Tunnel near Ajjampura in Tungabhadra sub-basin of Krishna basin. After Tunnel, through Chitradurga Branch Canal and Tumkur Branch Canal, it is planned to irrigate an extent of 2,25,515 ha by drip irrigation in districts of Chikmagalur, Chitradurga, Tumkur and Davangere. Out of 29.90 TMC of water, 19.04 TMC of water is earmarked for irrigation and remaining 10.86 TMC is allocated for filling of MI tanks. Ministry of Environment, Forests and Climate Change (MoEF&CC), Govt. of India accorded Environmental Clearance for the proposed project vide letter nos. J-12011/7/2009-IA.I dated 05.01.2010 and J-12011/7/2009-IA.I (Vol-II) dated 10.07.2017. The map showing the command area of the project is enclosed as Annexure-I.

Earlier, the proposed project involves diversion of 318.62 Ha of forest land for the construction of main canal from Tunga River to Bhadra Reservoir (96.95 Ha) for which the process for obtaining Stage-II Forest Clearance is under process; Bhadra Reservoir to Ajjampura tunnel (110.10 Ha) and Chitradurga Branch Canal (111.57 Ha) for which Stage II Forest Clearance has been obtained from MoEF&CC, GoI. However, in case of Chitradurga Branch Canal, the Forest Land requirement has been reduced to 91.89 Ha and the same has been communicated to Forest Department for onward submission to MoEF&CC.

The project components of Package-I of Upper Bhadra Project were proposed at a distance of 1 Km from the Bhadra Tiger Reserve and it falls within the ESZ of Bhadra Wildlife Sanctuary. In view of this, recommendation from NBWL was obtained vide Ltr. No. F. No. 6-119/2107 WL; dt: 21.07.2017.

Further, an additional forest land of 61 Ha belonging to Udugere RF (9.28 Ha) in Kadur Taluk, Chikkamagalur District and Bukkapatna RF (51.72 Ha) of Sira Taluk, Tumkur District is required for construction of Tumkur Branch Canal. Of which the proposed forest land to be diverted within Bukkapatna RF i.e., 51.32 Ha falls within the “Bukkapatna Chinkara Wildlife Sanctuary”. Hence, the proposal requires recommendation of NBWL through SBWL. The map showing the alignment of TBC in Bukkapatna Chinkara WLS is as given below;

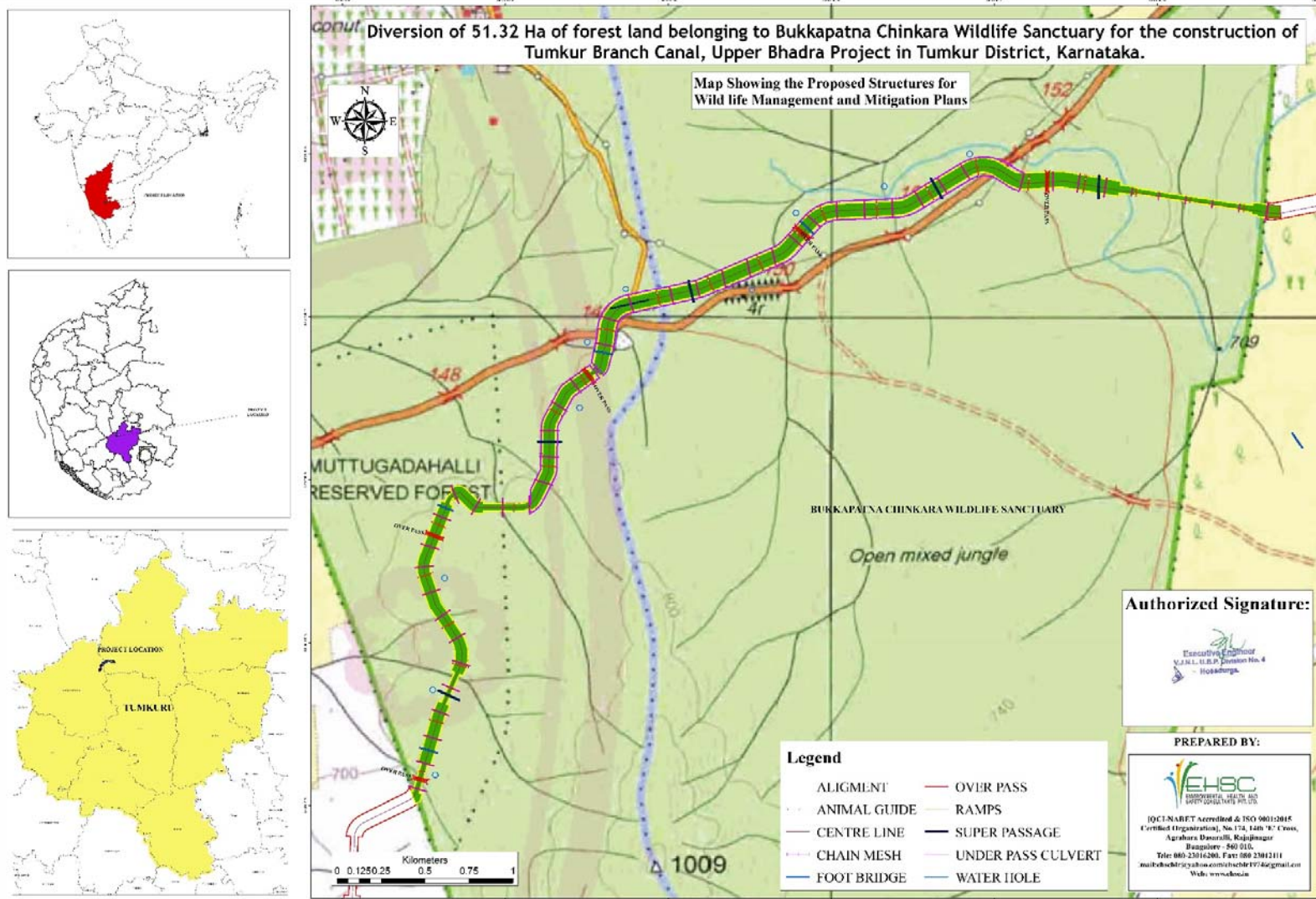

Figure 1 Map showing the location and alignment of Tumkur Branch Canal in Bukkapatna Chinkara WLS.

## **1.2 Need for the Project**

Challakere, Hiriyur, Holalkere, Molakalmuru and Hosadurga Taluks in Chitradurga district, Jagalur Taluk in Davanagere district and Chicknayakanahalli, Pavagada and Sira Taluks are declared as severely drought affected Taluks by Karnataka State Natural Disaster Monitoring Centre (KSNDMC). Most of the families in the district are Below Poverty Line (BPL) and the agriculture is dwindling due to the unusual rainfall. Agriculture is the main economic source of income coupled with low annual rainfall of the order of 574 mm is posing threat to the livelihood and income of the people. Large variance in annual rainfall and uncertainty within a year causes the agriculture a risky venture. The people of the region have no other employment opportunities except agriculture. Hence providing irrigation and stabilizing the agricultural production, provides a much needed relief to the people. It improves the per capita income and standard of living of the people.

Excessive use of nitrate based fertilizers in the aforesaid Taluks, as well as presence of fluoride underground has resulted in contamination of ground water. This has made water unpalatable and unhealthy for human consumption. Hence, there is a need to provide the drinking water for human and domestic consumption and recharging the existing tanks to dilute the excess salts is of primary concern.

In this context, the project aims at providing sustainable irrigation facilities in Kharif season, recharge the ground water table and provide drinking water by filling 367 tanks in drought-prone taluks of the above said districts.

The benefits of Tumkur Branch Canal (TBC) under Upper Bhadra Project are as follows;

1. The area under TBC is dry facing erratic rainfall and droughts that are common in the region and the TBC runs for about 158 Km from Ajjampura Tunnel thereby helps in mitigating drought conditions of the region.
2. A total of 375 villages will be benefitted upon implementation of TBC.

3. TBC is planning to irrigate 84,900 Ha of command area in Chikkamagalur District (22130 Ha), Chitradurga District (43555 Ha) and Tumkur District (19215 Ha).
4. The objectives of TBC include providing drinking water supply and underground recharge along with filling up of 131 MI tanks in 3 districts.

### **1.3 Need for Wildlife Management Plan**

Out of 61 Ha of forest land required for construction of Tumkur Branch Canal (TBC), 51.32 Ha of forest land belongs to Bukkapatna RF which has been notified as “Bukkapatna Chinkara Wildlife Sanctuary” vide GoK Notification No: FEE 63 FWL 2019; dt: 16.05.2019. The total area of the sanctuary is 13611.47 Ha which acts as a unique habitat for all 3 types of Antelopes viz., Four horned antelope, Black buck and Chinkara along with other Scheduled species such as Bear, Leopard, Hyena, Indian Wolf, etc. About 25 mammals, 12 amphibians, 28 reptiles, 54 butterflies and 160 avifaunal species are found in general in this forest.

Wildlife habitat is considered as the environment used by an animal and is essential for food, mating, cover and other requirements for survival. Any disturbance or loss of such habitat will have adverse effect on the overall population of the animals which live in that area. Whereas, linear projects such as irrigation canal is important to the country for economic growth and to meet the demands of basic needs of the people. Hence, incorporating the ecological considerations into modern design techniques will result in favorable win to win approach to safeguard the interests of both wildlife and people.

In this context, the objectives of the present Wildlife Management & Mitigation plan are as follows;

- To provide a plan to mitigate the impacts due to construction of canal inside the forest areas.
- To provide wildlife-crossings at suitable places, which are comfortable and conducive for wildlife movement across the proposed canal.

- There are no sources of water for the wildlife of the Bukkapatna Chinkara WLS except Boranakanive Lake located about 6 Km from the sanctuary and 2 non perennial lakes located within the sanctuary.
- To provide structures such as crossings, overpass bridges, culverts, water holes, etc so as not to disrupt the wildlife behaviour and its activities.
- To improve the habitat factors by augmenting the availability of water to wildlife during pinch period and by carrying out plantation of suitable species.
- To ensure the safety of wildlife by erecting chain link mesh fence along the canal abutting the NH-234 for about 4.5 Km to prevent road kills and accidental falls into the canal.
- There are no existing Wildlife structures proposed as part of NH-234 which is further proposed to be converted into a four lane highway. The Wildlife Management & Mitigation plan under TBC provides necessary wildlife crossings and structures essential for the wildlife activities and movements along the canal which abuts the NH-234 for about 4.5 Km length.
- Monitor of wildlife crossings and study the long-term impacts.

**2.1 TUMKUR BRANCH CANAL**

The Tumkur Branch canal involves diversion of 61 Ha of Forest land belonging to Udugere RF (9.28 Ha) in Kadur Taluk, Chikmagalur District, and Bukkapatna RF (51.72 Ha) of Sira Taluk, Tumkur District. Out of which an area of 51.32 Ha falls within Bukkapatna Chinkara WLS. The total length of Tumkur Branch Canal is 1,59,684 m; out of which, 7,62 m from CH 150.735 Km to CH.158.375 Km falls within the Bukkapatna Chinkara WLS. The proposed Tumkur Branch Canal abuts the NH-234 for about 4.5 Km from CH.153.785 to 156.875 Km within Bukkapatna Chinkara Wildlife Sanctuary. The proposed TBC passes along the middle of the Bukkapatna Chinkara WLS thereby avoiding creation of isolated fragments of the WLS. The proposed alignment of Tumkur Branch Canal was considered after carrying out detailed studies involving 4 alternatives at Bukkapatna RF. The proposed alignment was found to be techno-economically feasible since it was finalized based on the irrigation contours and is also considered to involve the barest minimum forest area compared to the other alternatives. The map showing alternative analysis for the proposed alignment of TBC is given as Annexure - II

The project attracts provisions of Forest (Conservation) Act, 1980 and Wildlife (Protection) Act, 1972 and requires approval from Regional Office, MoEF&CC and NBWL through SBWL respectively for diversion of Forest and Wildlife land. The application seeking prior approval of Central Government under Section 2 of Forest (Conservation) Act, 1980 has been submitted to the Deputy Conservator of Forest and District Commissioner of Tumkur and Chikmagalur Districts respectively on 18.07.2019 for onward site visits and Stage - I approval.

The SoI map and Geo-referenced maps showing the alignment of TBC in Bukkapatna Chinkara WLS are annexed as Annexure- III & IV respectively. The chainage wise details of forest land required for the construction of TBC along with GPRS Coordinates in Bukkapatna Chinkara Wildlife Sanctuary are as given below;

Table 1 Forest land required for diversion to construct Tumkur Branch Canal, Bukkapatna WLS.

Sr. No	Village Limits	Survey No	Chainage		Length of canal in Mtrs.	Canal width in Mtrs.	Land Required in ha
			From	To			
1	BELLARA	38	150735	150773	38	70	0.27
2		38	150773	150944	171	35	0.6
3		38	150944	151299	355	70	2.49
4		38	151299	151357	58	31	0.18
5						37	4
6		38	151357	151483	126	3	0.04
7						37	32
8		37	151483	151533	50	60	0.3
9						33	10
10		37	151533	151574	41	10	0.04
11						33	60
12		33	151574	151710	136	70	0.95
13		37	151710	151852	142	20	0.28
14						33	50
15		37	151852	152034	182	60	1.09
16						33	10
17		35	152034	152423	389	70	2.72
18		33	152423	152570	147	20	0.29
19						35	50
20		35	152570	152604	34	15	0.05
21						33	15
22		33	152604	152629	25	30	0.08
23		33	152629	152819	190	70	1.33
24		33	152819	152949	130	40	0.52
25		32	152949	153078	129	40	0.52
26		32	153078	153973	895	70	6.27
27		32	153973	154000	27	30	0.08
28		32	154000	154225	225	80	1.8
29		32	154225	154240	15	75	0.11
30						Road	5
31		32	154240	154267	27	4	0.01
32						31	5
33		Road				71	0.19
34		31	154267	154277	10	75	0.08
35		Road				5	0.01

Sr. No	Village Limits	Survey No	Chainage		Length of canal	Canal width	Land Required
36		31	154277	154573	296	80	2.37
<b>TOTAL</b>					<b>3838</b>		<b>25.08</b>
1	KANAVIRAMPURA	1	154573	156743	2170	80	17.36
<b>TOTAL</b>					<b>2170</b>		<b>17.36</b>
1	BUDDIGUDDADAKAVALU	22	156743	157022	279	80	2.23
2		22	157022	157044	22	60	0.13
3		23				20	0.04
4		22	157044	157068	24	10	0.02
5		23				70	0.17
6		23	157068	157453	385	80	3.08
7		23	157453	157543	90	40	0.36
8		23	157543	158123	580	25	1.45
9		23	158123	158195	72	35	0.25
10		23	158195	158228	33	70	0.23
11		23	158228	158282	54	75	0.41
			39	158282	158375	76	65
<b>TOTAL</b>					<b>1539</b>		<b>8.88</b>
<b>TOTAL EXTENT IN BUKKAPATNA CHINKARA WLS</b>					<b>7547</b>		<b>51.32</b>

Table 2: GPRS Coordinates of Forest land to be diverted for the construction of Tumkur Branch Canal in Bukkapatna Chinkara WLS.

Sl.No	GPRS Point	Latitude	Longitude	Sl.No	GPRS Point	Latitude	Longitude
1	Sp 1	13.600100°	76.687075°	39	Dp 56	13.615620°	76.689325°
2	Dp 3	13.600209°	76.687292°	40	Dp 56	13.615620°	76.689325°
3	DP 4	13.600582°	76.687401°	41	Dp 58	13.615536°	76.689417°
4	Dp 5	13.600629°	76.687255°	42	Dp 60	13.615455°	76.689492°
5	Sp 3	13.601042°	76.687374°	43	Dp 62	13.615156°	76.689811°
6	Sp 6	13.601545°	76.687523°	44	Dp 64	13.615040°	76.689967°
7	Dp 5	13.602108°	76.687685°	45	Dp 66	13.614968°	76.690222°
8	Dp 7	13.602073°	76.687843°	46	Dp 68	13.614965°	76.690534°
9	Sp 7	13.602828°	76.688063°	47	Dp 69	13.615093°	76.690537°
10	SP 9	13.603684°	76.688312°	48	Sp 20	13.615105°	76.691049°
11	SP 11	13.604525°	76.688558°	49	Sp 22	13.615092°	76.691756°
12	Dp 9	13.605090°	76.688806°	50	Sp 24	13.615080°	76.692252°
13	Dp 10	13.605158°	76.688646°	51	Sp 26	13.615092°	76.692557°
14	Sp 14	13.605832°	76.688940°	52	Dp 72	13.615209°	76.692922°
15	DP 13	13.606683°	76.689314°	53	Dp 73	13.615078°	76.692922°
16	DP 15	13.606630°	76.689470°	54	Dp 76	13.615199°	76.693123°

Sl.No	GPRS Point	Latitude	Longitude	Sl.No	GPRS Point	Latitude	Longitude
17	DP 17	13.607191°	76.689693°	55	Dp 77	13.615340°	76.693280°
18	Dp 19	13.607645°	76.689745°	56	Dp 78	13.615597°	76.693476°
19	Dp 21	13.608150°	76.689684°	57	Sp 27	13.616142°	76.693750°
20	Dp 23	13.608744°	76.689458°	58	Sp 29	13.616692°	76.694031°
21	Dp 25	13.609258°	76.689106°	59	Sp 31	13.616892°	76.694119°
22	Dp 27	13.609838°	76.688728°	60	Sp33	13.617040°	76.694171°
23	DP 29	13.610354°	76.688382°	61	Sp 35	13.617208°	76.694193°
24	Dp 31	13.611658°	76.687910°	62	Sp 37	13.617374°	76.694194°
25	Dp 33	13.612014°	76.687824°	63	Sp 39	13.618318°	76.694211°
26	Dp 35	13.612318°	76.687809°	64	Sp 40	13.619401°	76.694231°
27	Dp 37	13.612622°	76.687892°	65	Sp 43	13.619554°	76.694280°
28	SP 13A	13.613301°	76.688186°	66	Sp 45	13.620946°	76.695029°
29	Sp 15	13.614044°	76.688448°	67	Sp 47	13.621495°	76.695753°
30	Sp 17	13.614676°	76.688706°	68	Dp 80	13.621841°	76.696245°
31	Dp 41	13.615353°	76.688980°	69	Dp 81	13.621977°	76.696147°
32	Dp 39	13.615428°	76.688819°	70	Dp 83	13.622125°	76.696358°
33	Dp 43	13.615618°	76.688901°	71	Dp 86	13.621954°	76.696496°
34	Dp 45	13.615724°	76.688969°	72	Dp 87	13.622114°	76.696715°
35	Dp 47	13.615744°	76.689000°	73	Dp 88	13.622286°	76.696840°
36	Dp 49	13.615557°	76.689070°	74	Sp 49	13.622797°	76.696971°
37	Dp 51	13.615656°	76.689158°	75	Sp 51	13.623586°	76.697132°
38	Dp 53	13.615702°	76.689248°	76	Sp 53	13.624534°	76.697267°
82	Sp 55	13.624703°	76.697314°	125	Sp 86	13.632395°	76.717745°
83	Sp 57	13.624891°	76.697430°	126	Sp 83	13.632797°	76.717123°
84	Sp 59	13.625138°	76.697665°	127	Sp 81	13.633118°	76.716238°
85	Sp 63	13.625267°	76.697985°	128	Sp79	13.632970°	76.715365°
86	Sp 64	13.625643°	76.699684°	129	Sp 77	13.630996°	76.712010°
87	Sp 66	13.626112°	76.701661°	130	Sp 75	13.630924°	76.711546°
88	Sp 68	13.627911°	76.705903°	131	Sp 73	13.630635°	76.707867°
89	Sp 70	13.629669°	76.707592°	132	Sp 71	13.630280°	76.707199°
90	Sp 72	13.629987°	76.708201°	133	Sp 69	13.628582°	76.705623°
91	Sp 74	13.630188°	76.711517°	134	Sp 67	13.626813°	76.701458°
92	Sp 76	13.630283°	76.712153°	135	Sp 65	13.626357°	76.699545°
93	Sp 78	13.632299°	76.715625°	136	Sp 64	13.625947°	76.697713°
94	Sp 80	13.632355°	76.716325°	137	Sp 62	13.625799°	76.697381°
95	Sp 82	13.632043°	76.716913°	138	Sp 61	13.625628°	76.697127°
96	Sp 85	13.631669°	76.717611°	139	Sp 60	13.625455°	76.696955°
97	Sp 87	13.631588°	76.718397°	140	Sp 58	13.625183°	76.696740°
98	Sp 89	13.631641°	76.719212°	141	Sp 56	13.624936°	76.696615°

Sl.No	GPRS Point	Latitude	Longitude	Sl.No	GPRS Point	Latitude	Longitude
99	Sp 91	13.631690°	76.719998°	142	Sp 54	13.624607°	76.696525°
100	Sp 93	13.631196°	76.723012°	143	Sp 52	13.623789°	76.696432°
101	Sp 95	13.631373°	76.723059°	144	Sp 50	13.623181°	76.696312°
102	Sp 97	13.631260°	76.723878°	145	Dp 89	13.622623°	76.696177°
103	Sp 99	13.631330°	76.723900°	146	Dp 85	13.622537°	76.696055°
104	Sp 101	13.630534°	76.729191°	147	Dp 84	13.622351°	76.696183°
105	Sp 102	13.630489°	76.729189°	148	Dp 82	13.622220°	76.695989°
106	Sp 105	13.630383°	76.729839°	149	Dp 79	13.622362°	76.695876°
107	Sp 107	13.630265°	76.729828°	150	Sp 48	13.622006°	76.695383°
108	Sp 109	13.630217°	76.730115°	151	Sp 46	13.621336°	76.694528°
109	Sp 111	13.630167°	76.730122°	152	Sp 44	13.619852°	76.693708°
110	Sp 113	13.630093°	76.730607°	153	Sp 42	13.619726°	76.693654°
111	Sp 114	13.630756°	76.730702°	154	Sp 41	13.619508°	76.693603°
112	Sp 112	13.630834°	76.730225°	155	Sp 38	13.618336°	76.693564°
113	Sp 110	13.630817°	76.730216°	156	Sp 36	13.617509°	76.693548°
114	Sp 108	13.630856°	76.729922°	157	Sp 34	13.617352°	76.693551°
115	Sp 106	13.630702°	76.729889°	158	Sp 32	13.617209°	76.693540°
116	Sp 104	13.630802°	76.729237°	159	Sp 30	13.616997°	76.693469°
117	Sp 103	13.630765°	76.729234°	160	Sp 28	13.616532°	76.693233°
118	Sp 100	13.631565°	76.723939°	161	Sp 28	13.616532°	76.693233°
119	Sp 98	13.631613°	76.723937°	162	Dp 75	13.615969°	76.692938°
120	Sp 96	13.631733°	76.723124°	163	Dp 74	13.615686°	76.692928°
121	Sp 94	13.631917°	76.723136°	157	Dp 71	13.615564°	76.692778°
122	Sp 92	13.632402°	76.719957°	158	Sp 25	13.615461°	76.692559°
123	Sp 90	13.632356°	76.719286°	159	Sp 23	13.615446°	76.692312°
124	Sp 88	13.632308°	76.718476°	160	Sp 21	13.615443°	76.691768°
161	Sp 19	13.615447°	76.691094°	185	Dp 28	13.609587°	76.688123°
162	Dp 70	13.615462°	76.690541°	186	Dp 26	13.609038°	76.688476°
163	Dp 67	13.615597°	76.690527°	187	Dp 24	13.608594°	76.688780°
164	Dp 65	13.615612°	76.690258°	188	Dp 22	13.608187°	76.689004°
165	Dp 63	13.615751°	76.690106°	189	Dp 20	13.607735°	76.689098°
166	Dp 61	13.616031°	76.689816°	190	Dp 18	13.607313°	76.689051°
167	Dp 59	13.616205°	76.689646°	191	DP 16	13.606876°	76.688881°
168	Dp 57	13.616322°	76.689465°	192	Dp 14	13.606794°	76.689055°
169	Dp 54	13.616352°	76.689212°	193	Sp 13	13.605953°	76.688695°
170	Sp 52	13.616298°	76.689020°	194	Dp 11	13.605273°	76.688394°
171	DP 50	13.616212°	76.688848°	195	DP 12	13.605337°	76.688214°
172	Dp 48	13.616026°	76.688909°	196	SP 12	13.604733°	76.687950°
173	Dp 46	13.615947°	76.688820°	197	Sp 10	13.603928°	76.687716°

Sl.No	GPRS Point	Latitude	Longitude	Sl.No	GPRS Point	Latitude	Longitude
174	Dp 44	13.615810°	76.688703°	198	SP 8	13.603065°	76.687460°
175	Dp 40	13.615533°	76.688562°	199	Dp 8	13.602247°	76.687220°
176	Dp 42	13.615601°	76.688384°	200	Dp 6	13.602203°	76.687379°
177	Sp 18	13.614918°	76.688111°	201	Sp 5	13.601654°	76.687221°
178	Sp 16	13.614330°	76.687882°	202	Sp 4	13.601137°	76.687064°
179	Sp 14	13.613611°	76.687607°	203	Dp 2	13.600718°	76.686941°
180	Dp 38	13.612795°	76.687260°	204	Dp 1	13.600743°	76.686823°
181	Dp 36	13.612402°	76.687175°	205	Sp 2	13.600353°	76.686971°
182	Dp 34	13.612005°	76.687165°				
183	DP 32	13.611591°	76.687248°				
184	Dp 30	13.610132°	76.687770°				

Table 3: Additional area sought during RFO Filed Visit

20 M GPS Co-ordinates of Budiguddadakavalu (Sy, No. 39)			
Sl.No	GPS Point	Latitude	Longitude
1	A1	13.6308	76.7307
2	A2	13.6308	76.7309
3	A3	13.6308	76.7311
4	A4	13.6307	76.7313
5	A5	13.6306	76.7313
6	A6	13.6304	76.7313
7	A7	13.6303	76.7313
8	A8	13.6301	76.7313
9	A9	13.6301	76.7311
10	A10	13.6301	76.7309
11	A11	13.6301	76.7307
12	A12	13.6302	76.7306
13	A13	13.6303	76.7306
14	A14	13.6305	76.7307
15	A15	13.6307	76.7307
16	A16	13.6308	76.7307

The forests of Tumkur Division consist of a wealth of deciduous species topping a thorny undergrowth typical of maidan areas of Karnataka. According to Champion & Seth (1968), Tumkur Forest Division falls under group five of Southern tropical dry deciduous forests. Low, stunted, brandy poles, and diffuse crown contribute to make up a patchy forest canopy. The tree growth is poor on account of many unfavorable factors such as inadequate rainfall, poor shallow soils and biotic factors.

### 3.1 Flora in Bukkapatna Chinkara WLS

- The forest area (Bukkapatna Chinkara WLS) proposed for diversion belongs to Bukkapatna Range of Tumkur Division.
- According to Champion & Seth (1968), the forest land of Bukkapatna Chinkara WLS belongs to the category “Dry thorny scrub forests”.
- Due to biotic factors like lopping, felling, excessive grazing, recurrent fires, poor and unevenly distributed rainfall and hilly nature, large areas of dry deciduous forests have degraded to poorer forest types.
- The trees tends to be bushy and stunted and do not grow more than five meters tall.
- The tree components are almost same as in dry deciduous forests but are distributed sparsely and vary very much in frequency of their occurrence.
- The main tree species includes *Acacia sp.*, *Albizia amara*, *Anogeissus latifolia*, *Bauhinia racemosa*, *Butea monosperma*, *Dalbergia paniculata*, *Ixora arborea*, *Semecarpus anacardium*, *Strychnos potatorum*, *Wrightia tinctoria*, *Tectona grandis*, *Grewia hirsuta*, *Morinda pubescens*, *Hardwickia binata*, *Phyllanthus emblica*, *Cassia fistula*, *Eucalyptus citriodora* and *Albizia lebbeck*.
- The undergrowth has *Canthium parviflora*, *Erythroxylum monogynum*, *Randia dumetorum*, *Pterolobium hexapetalum*, *Lantana camara*, *Dodonaea viscosa*, *Cassia auriculata* and others.

### 3.2 Demand & timber and non-timber forest produce

The important forest products of utility in the division are timber, small timber, non-timber forest products like tamarind, seethaphala, maradi seeds, honey wax, thatching grass, medicinal plants, myrobolams, *Eucalyptus* and *Casuarina* poles. In general the following are the species identified in the forests of division which cater to the needs of timber, small timber, non-timber forest products, fruits, fodder and other cultural needs. Industrial requirement of mineral is also met to some extent. The cement factory at Ammasandra is the principal consumer of limestone quarried from nearby forests.

- **Timber and small timber:** *Acacia nilotica*, *Acacia auriculiformis*, *Albizia spp*, *Azadirachta indica*, *Eucalyptus* and *Casuarina* poles.
- **Bamboo:** *Dendrocalamus strictus*, *Bambusa bambos*.
- **Non-timber forest products:** *Tamarindus indica*, *Diospyros sp*, *Annona squamosa*, *Buchanania spp*, myrobolams, honey and medicinal plants.
- **Trees considered culturally important:** *Aegle marmelos*, *Azadirachta indica*, *Ficus bengalensis*, *Ficus religiosa*, *Madhuca indica* etc.
- **Minerals:** Iron, manganese and limestone.



#### 4.1 Fauna in thorn and scrub forests of Tumkur Division

Though the forest cover is not substantial, the forests are inhabited by a variety of animal life. However, larger animals are scarce in the district. The predominant fauna of the thorn and shrub forests of Tumkur Division includes Sloth bears, Black bucks, Wild sheeps, panthers and hares. Some of the other fauna in the Division includes;

- **Mammals:** Common langur, Common fox, Fruit bat, Hyena, Indian porcupine, Indian wolf, Jackal, Jungle cat, Mice, Mongoose, Rat, Squirrel, Spotted deer, Wild boar.
- **Birds:** Ashy wren warbler, Black drongo, Black winged kite, Blossom headed parakeet, Blue Jay, Black headed oriole, Common weaver bird, Crow pheasant, Chestnut bellied nut hatch, Common myna, Common hawk, Cattle egret, Common peafowl, Common kingfisher, Grey babbler, Grey wagtail, Grey jungle fowl, Great horned owl, Gray partridge, Golden backed woodpecker, House sparrow, Indian robin, Jungle Babbler, Jungle myna, Jungle crow, Koel, Luggar falcon, Munia, Pied wagtail, Pariah kite, Red vented bulbul, Red turtledove, Rose ringed parakeet, Whistling thrush.
- **Reptiles:** Cobra, Chameleon, Garden lizard, Krait, Monitor lizard, Python, Viper.

#### 4.2 Fauna in Bukkapatna Chinkara WLS

The total area of the sanctuary is 13611.47 Ha which acts as a unique habitat for all 3 types of Antelopes viz., Four horned antelope, Black buck and Chinkara along with other Scheduled species such as sloth bear, Leopard, Hyena, Indian Wolf, etc. About 25 mammals, 12 amphibians, 28 reptiles, 54 butterflies and 160 avifaunal species are found in general in this forest.

#### 4.2.1 Conservation status of mega-faunal species in Bukkapatna Chinkara WLS

Table 3: IUCN conservation status, 2019 and Wildlife (Protection) Act, 1972 of the mega-faunal species recorded in Bukkapatna Chinkara WLS

Sl. No.	Common Name	Scientific Name	IUCN Conservation status, 2019	Wildlife (Protection) Act, 1972 Schedule
1	Four horned antelope	<i>Tetracerus quadricornis</i> (Blainville, 1816)	Vulnerable	I
2	Black buck	<i>Antilope cervicapra</i> (Linnaeus, 1758)	Least Concern	I
3	Chinkara	<i>Gazella bennettii</i> (Sykes, 1831)	Least Concern	I
4	Sloth bear	<i>Melursus ursinus</i> (Shaw, 1791)	Vulnerable	I
5	Leopard	<i>Panthera pardus</i> (Linnaeus, 1758)	Vulnerable	I
6	Striped Hyena	<i>Hyaena hyaena</i> (Linnaeus, 1758)	Near Threatened	III
7	Indian Wolf	<i>Canis lupus pallipes</i> (Sykes, 1831)	Not Assessed	I

The conservation aspects for the preparation of Wildlife Management & Mitigation Plan of the above mega-fauna are arrived based on their behaviour, preferable habitats, breeding sites, food and water availability in the region. The details are as given below;

Table 4: Conservation aspects of mega-faunal species recorded in Bukkapatna Chinkara WLS

Species	Behavior	Habitat & breeding site	Food	Conservation aspects to be considered
Black buck	<ul style="list-style-type: none"> <li>Primarily grazers, but browse when lack of grasses.</li> <li>Mainly sedentary, but in summer may move longer distances in search of water and forage.</li> <li>Require water every day.</li> </ul>	<ul style="list-style-type: none"> <li>Open grassland, dry thorn scrub, scrubland and lightly-wooded country as well as agricultural margins.</li> </ul>	Grasses, leaf litter, flowers and fruits	<ul style="list-style-type: none"> <li>Wildlife crossings to provide accessibility to the resources on the other side of the canal.</li> <li>Water holes for drinking purpose.</li> <li>Plantation of flower and fruit bearing species along</li> </ul>

Species	Behavior	Habitat & breeding site	Food	Conservation aspects to be considered
				the canal banks and overpass bridges.
Chinkara	<ul style="list-style-type: none"> <li>• Shy and avoid human habitation.</li> <li>• Nocturnal feeding habits and are most active just prior to sunset and throughout the night.</li> <li>• They are facultative drinkers, and so can live in very arid areas without water for long periods.</li> <li>• They sometimes raid fields cultivated with rape seed and sorghum in desert regions</li> </ul>	<ul style="list-style-type: none"> <li>• Arid plains and hills, deserts, dry scrub and light forests.</li> </ul>	<ul style="list-style-type: none"> <li>• Their diet typically consists of grasses, herbs, various leaves, crops and fruits.</li> <li>• Herbs preferred includes; <i>Crotalaria burhia</i> (42% of diet), <i>Ziziphus nummularia</i> (15%), <i>Maytenus emerginata</i> (11%), and <i>Prosopis cineraria</i> (9%).</li> </ul>	<ul style="list-style-type: none"> <li>• Wildlife crossings to provide accessibility to the resources on the other side of the canal.</li> <li>• Plantation of fruit bearing trees along with preferred herbs along the canal banks and overpass bridges.</li> </ul>
Four horned antelope	<ul style="list-style-type: none"> <li>• Primarily grazers, but browse when lack of grasses.</li> <li>• Diurnal and solitary by nature.</li> </ul>	<ul style="list-style-type: none"> <li>• Open grassland, dry thorn scrub, scrubland and lightly-wooded country as well as agricultural margins.</li> <li>• Habitats close to water bodies.</li> </ul>	Grasses, herbs, shrubs, foliage, flowers and fruits.	<ul style="list-style-type: none"> <li>• Wildlife crossings to provide accessibility to the resources on the other side of the canal.</li> <li>• Water holes for drinking purpose. Plantation of flower and fruit bearing trees along the canal banks and overpass bridges.</li> <li>• Plantation of flower and fruit bearing species along the canal banks and overpass bridges.</li> </ul>

Species	Behavior	Habitat & breeding site	Food	Conservation aspects to be considered
Indian wolf	<ul style="list-style-type: none"> <li>• Social animal and live in small packs.</li> <li>• Territorial.</li> <li>• Nocturnal</li> </ul>	<ul style="list-style-type: none"> <li>• Ubiquitous where there is suitable food and prey biomass is highest.</li> </ul>	Extremely variable food including moose, caribou, deer, wild boar, smaller prey items, livestock, carrion, garbage, etc.	<ul style="list-style-type: none"> <li>• Wildlife crossings to provide accessibility to the resources on the other side of the canal.</li> <li>• Water holes for drinking purpose.</li> </ul>
Leopard	<ul style="list-style-type: none"> <li>• Solitary and nocturnal carnivores.</li> <li>• Less diurnal in areas close to human habitats.</li> <li>• Most comfortable in the lower forest canopy, where they often feed, and descend from the canopy head-first.</li> <li>• Comfortable in water and are adequate swimmers.</li> <li>• Carries the carcass to a secluded feeding location, typically in a nearby tree.</li> <li>• Rest in the branches of trees with dense canopies in order to escape the heat of the day and increase their sense of safety.</li> </ul>	<ul style="list-style-type: none"> <li>• Leopards inhabit a variety of terrain.</li> <li>• Also occupies mountainous, scrub, and desert habitats.</li> <li>• Favor trees throughout their entire geographic distribution.</li> </ul>	<ul style="list-style-type: none"> <li>• Mid-sized ungulates, which includes small antelopes (Bovidae), gazelles (Gazella), deer (Cervidae), pigs (Sus), primates (Primates) and domestic livestock.</li> <li>• Also feeds on birds (Aves), reptiles (Reptilia), rodents (Rodentia), arthropods (Arthropoda), and carrion when available.</li> <li>• Facultative drinkers and obtain much of their water requirements from ingested prey.</li> </ul>	<ul style="list-style-type: none"> <li>• Wildlife crossings to provide accessibility to the resources on the other side of the canal.</li> <li>• Plantation of trees with dense canopies along the canal banks.</li> </ul>
Sloth bear	Nocturnal or crepuscular	<ul style="list-style-type: none"> <li>• Wide range of habitats including wet and dry tropical forests, savannahs, scrublands, and grasslands. It shelters in rock outcrops,</li> </ul>	Termites, ants, and fruits	<ul style="list-style-type: none"> <li>• Wildlife crossings and culvert boxes to provide accessibility to the resources on the other side of the canal.</li> </ul>

Species	Behavior	Habitat & breeding site	Food	Conservation aspects to be considered
		thickets, and tree cavities.		<ul style="list-style-type: none"> <li>• Water holes for drinking purpose.</li> <li>• Plantation of fruit bearing trees along the canal banks and overpass bridges.</li> </ul>
Striped Hyena	<ul style="list-style-type: none"> <li>• Generally considered solitary, but has some social organization.</li> <li>• Forages individually principally at night and is rarely seen in groups.</li> <li>• Water is consumed every night if it is available, but can survive without water for long periods and live under desert conditions.</li> </ul>	<ul style="list-style-type: none"> <li>• Arid, mountainous regions with scrub woodland. It dens in rocky hills, ravines, and crevices.</li> </ul>	<ul style="list-style-type: none"> <li>• Predominantly a scavenger.</li> <li>• Diet consists mainly of carrion and human refuse.</li> <li>• Scavenges large and medium-sized mammals, such as zebras, wildebeests, gazelles, and impalas, even eating bones from carcasses if the meat has been picked off.</li> <li>• Supplements its diet with fruit, insects, and occasionally by killing small animals like hare, rodents, reptiles, and birds.</li> </ul>	<ul style="list-style-type: none"> <li>• Wildlife crossings to provide accessibility to the resources on the other side of the canal.</li> <li>• Water holes for drinking purpose.</li> </ul>

### **5.1 Habitat Fragmentation**

Habitat fragmentation is defined as a process during which 'a large area of habitat is transformed into a number of smaller patches of smaller total area, isolated from each other by a matrix of habitats unlike the original' (Wilcove *et al.* 1986).

Out of 1,59,684 m of the TBC, 7,62 m (CH 150.735 Km to CH.158.357 Km) of the canal falls within the Bukkapatna Chinkara WLS. Construction of the canal acts as a physical barrier for wildlife. The species belonging to the area proposed for canal construction will lose their habitat and fragmentation will take place. Animal movement will be blocked and chances of animals fall into the canal result in death or injury.

Bukkapatna Chinkara WLS is a unique habitat for antelopes, sloth bears, leopards, wolves, etc. However, these mammals are not confined to a particular place and move across and between the nearby Reserve Forests. Therefore, the construction of the canal may cause habitat fragmentation but with suitable mitigation measures such as, wildlife crossings, overpasses, underpasses, bridges, etc can be constructed to minimize the effect of habitat fragmentation.

### **5.2 Loss of Habitat**

The area proposed for diversion is a habitat for antelopes and sloth bears along with other species. Habitat loss has direct negative effect on genetic diversity and population growth rate. Habitat loss occurs when an area of suitable habitat is altered and becomes unsuitable leading to displacement of resident species. However, landscape as a whole, the area proposed for diversion is small (0.37 % of the total area) and any changes occurred would be recoverable with appropriate mitigation measures.

### **5.3 Disturbance during project implementation**

Impacts due to labour force for construction activities will lead to establishment of campsites, generation of sewage, waste water and solid waste. Further, they may engage in activities that are detrimental to natural habitat such as hunting, illegal extraction of timber for fuel wood and non timber forest products.

Air and noise pollution will arise due to activities such as excavation, cutting, drilling and filling and compaction work, as well as operation of construction related vehicles during the construction phase will cause disturbance to the wild animals. This can be avoided by following appropriate mitigative measures.

#### **5.4 Road kills/accidental fall into canal**

The alignment of TBC for a stretch of 4.5 km abuts the NH-234 which may lead to road kills of wildlife during its movement to the other side of the canal. Drowning or accidental fall of animal's especially small and medium sized animals into the canal will result in death or injury to these animals. This can be avoided with erection of chain link mesh based fencing on either sides of the canal.

The impacts stated in Chapter 5 can be minimized through several mitigation measures which are a part of the Wildlife Management Plan. The mitigation measures are as follows;

### **6.1 Provision of wildlife crossings**

Wildlife, like any other living species require the primary needs of food, shelter, water and territory to roam, hunt, search for food etc. The construction of canal in the WLS may pose as a barrier restricting the movement of animals. Daily, weekly or seasonal movements across landscape is necessary for the most terrestrial species.

It may not be a serious threat for the smaller mammal and other terrestrial species but the large mammals may get highly affected. This leads to habitat fragmentation and the major impacts are as follows (Jaeger et. al., 2005);

- Limits the availability of habitat for any wild species
- Prevents access to water and other resources on the other side of the canal
- Subdivide wildlife populations into smaller and more vulnerable sub-populations
- Affects the regular movement path of the wildlife

Hence it is necessary to construct wildlife crossings in order to facilitate the smooth movement of animals all through its natural habitat. The crossing over construction is necessary for the following elements:

- To restore pre-development wildlife movement pattern
- To reduce wild life physical barrier due to canals

These structures allow animals to cross human-made barriers safely. These crossings may include: underpass tunnels, viaducts, and overpasses (mainly for large or herd-type animals); amphibian tunnels; tunnels and culverts (for small mammals); green roofs (for butterflies and birds) (Bank et al. 2002). All of these structures are designed to provide semi-natural corridors above and below human constructed barriers like canals so that animals can safely cross without endangering themselves.

Wildlife crossings are a practice in habitat conservation, allowing connections or reconnections between habitats, combating habitat fragmentation. They also assist in avoiding falling and drowning of animals in the canals. Some of the examples of the wildlife crossing across the world are given below;

Site selection for the construction of the wild life crossing (Overpass or Underpass) construction has to consider the following factor;

- Multiple crossing structures should be constructed keeping in view of the water bodies within the WLS and at a crossing point to provide connectivity for all species likely to use a given area with water availability (Little, 2003). Different species prefer different types of structures (Clevenger et al. 2001; McDonald & St Clair 2004; Clevenger & Waltho 2005; Mata et al. 2005). For deer or other ungulates, bridge is preferable and for black bear, large box culverts with natural earthen substrate flooring are optimal (Evink, 2002).
- At least one crossing structure should be located within an individual's home range. Because most reptiles, small mammals, and amphibians have small home ranges, metal or cement box culverts should be installed at intervals of 150-300m (Clevenger et al. 2001). For ungulates and large carnivores, larger crossing structures should be located no more than 1.5 km apart (Mata et al. 2005; Clevenger and Wierzchowski 2006).
- Suitable habitat for species should occur on both sides of the crossing structure (Ruediger 2001; Barnum 2003; Cain et al. 2003; Ng et al. 2004).

Considering the above points and views of animals using the location, topography and observations of forest officials, following wildlife crossings were suggested;

<b>Sl. No.</b>	<b>Proposed Structure</b>	<b>Criteria</b>	<b>No of structures proposed</b>
1	Single lane (Over pass) bridges	One for every 1500 m	5 Nos.
2	Under passes/ culverts	One for every 150 m	50 Nos.
3	Super passages	One for every 1500 m	5 Nos.
4	Foot bridges	One for every 1500 m	5 Nos.
5	Water holes	One for every 500 m	15 Nos.
6	Animal Guide	One for every 300 m	25 Nos.

Sl. No.	Proposed Structure	Criteria	No of structures proposed
7	Ramps	One for every 300 m	25 Nos.
8	Chain link mesh on either sides of canal	CH.153.785 to 156.875 Km near NH-234	For approximately 4.5 Km

### 6.1.1 Single Lane (over pass) bridges

Single lane bridges are structures built across the canal for easy movement of mega faunal species such as, Blackbuck, Hyena, Jackal, Panther, Sloth bear, Spotted deer, Four horned antelope, Chinkara, Indian fox, Indian wolf, etc. The floor of these bridges of 15 m width will be covered with soil and vegetation to make the movement more comfortable. These structures will be built at 5 places for every 1500 m along Tumkur Branch Canal within the WLS. Construction of single lane bridge near this linkage help the mega fauna to crossover to the other side of the canal for the accessibility of water and other resources.

### 6.1.2 Underpasses (culverts)

Underpasses (Box culverts) are structures meant for flow of water under the canal. Fifty underpass bridges/culverts of 2 m width will be constructed for every 150 m of Tumkur Branch Canal within WLS as it will help in the movement of vast population of sloth bears along with other small, medium animals and reptiles. There might be a regular wildlife movement near to this chain linkage due to available water source. Construction of the passage in this area help the easy movement of the wildlife without disturb in their regular movement.



Figure 2: Typical view of culvert

### **6.3 Super passages**

Super passage is a hydraulic structure in which the natural drainage is passing over the irrigation canal. The drainage is taken through a rectangular or trapezoidal trough of channel which is constructed on the deck supported by piers. Smaller mammals and reptiles such as porcupine, hare, mongoose, snakes, etc can make use of this structure for their movement easily. Five super passages of 3 m width will be constructed for every 1500 m of Tumkur Branch Canal within WLS.

### **6.4 Foot bridges**

Foot bridge is a structure designed for low mobile mammals and reptiles and lower order animals and provides safe and sustainable crossings. These structures are provided with RC railings for safe movement. Five foot bridges will be constructed for every 1500 m along Tumkur Branch Canal within WLS.

## **6.2 Mitigation of impacts during project implementation phase**

- Water shall be sprayed by high-pressure water hoses during dust generating construction activities e.g. excavation, crushing/demolishing, concrete mixing, material handling etc. to suppress dust; and vehicles delivering loose and fine materials like sand and fine aggregates shall be covered by tarpaulin to reduce spills on roads.
- All roads (internal and external) to be used by the project authorities should be made 'pucca' (Sprinkled with water) to mitigate the dust generation along the roads.
- Exhausts of other equipment used for construction (e.g. generators), if any shall be positioned at a sufficient height to ensure dispersal of exhaust emissions and meet the standards set by CPCB. Idle running of vehicles will be minimized during transport and handling activities.
- The noise pollution will be checked and maintained by installing sound barricades around crushing plants and by taking up regular maintenance of heavy earth moving vehicles. Selection of equipment with less noise generation will be used.

- On site workers near the noise generating equipment shall be provided with noise protection devices like earmuffs/earplugs. Controlled blasting and drilling will be undertaken to avoid the noise pollution.
- No labor camps are allowed inside the forest areas.
- Labors will be trained for protection of trees and conservation and importance of wildlife. Smoking is prohibited in the forest areas and regular monitoring will be undertaken to avoid forest fires.
- Labor camps will be provided with LPG for cooking and hence illegal felling of trees will be avoided.
- During construction phase, forest department will depute staff to monitor the activities.

### **6.3 Provision for chain link mesh**

Erection of chain link mesh based fencing on either side of the canal (4.5 Km length from CH.153.785 to 156.875 Km near NH-234) to secure wild animals from road kills and accidental fall leading to drowning in the canal. The fence type is metal with high gauge and more durable. Habitat improvement through raising of plantations and providing water holes is increased in the density of animals in that area.

### **6.4 Augmenting the factors of habitat**

#### **6.4.1 Creation of water holes**

Generally during summer, drowning of animals into the canal will be anticipated to access the drinking water. In order to avoid the drowning of animals due to drinking water, artificial water holes will be created with continuous water supply from the canal throughout the year. Water holes of not less than 700 Sq. m. area will be proposed at every 500 m and the water will be supplied with the canal water through piped conveyance system. A total of 15 water holes are proposed to cater the drinking water needs of wildlife.



Figure 3: Typical view of water holes

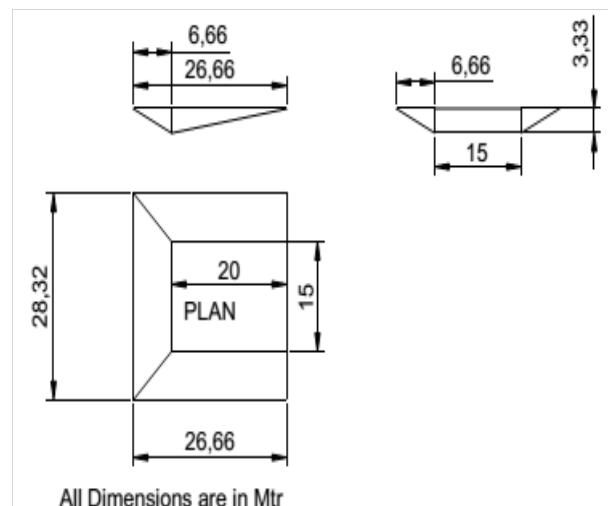

Figure 4: Typical design of water holes

#### 6.4.2 Plantation along canal banks

In order to enhance greenery along the barriers across canal so as create a natural and comfortable environment to the wildlife, plantation of tall, greater crown, broad leaved,

fruit bearing, shade providing trees shall be planted. The plantation will be taken up in due consultation with KFD and species proposed for plantation is given below.

Table 5: Checklist of native tree species proposed for plantation alongside canals

<b>A. Canal Bank Plantation</b>				
<b>Sl.No</b>	<b>Scientific Name</b>	<b>Common Name</b>	<b>Family</b>	<b>Uses</b>
1	<i>Aegle marmelos</i> (L.) Corrêa	Bilvapatre	Rutaceae	Edible
2	<i>Alangium salvifolium</i> (Lam.)	Ankole	Cornaceae	Fruit
3	<i>Anacardium occidentale</i> L.	Gerubeeja	Anacardiaceae	Fruit
4	<i>Swietenia mahagoni</i> (L.) Jacq.	Mahogany	Meliaceae	Shade
5	<i>Azadirachta indica</i> A.Juss.	Bevu	Meliaceae	Shade
6	<i>Terminalia chebula</i> Retz.	Alale kaayi	Combretaceae	Shade
7	<i>Ficus benghalensis</i> L.	Aladamara	Moraceae	Fruit
8	<i>Ficus racemosa</i> L.	Attimara	Moraceae	Fruit
9	<i>Annona squamosa</i> L.	Seetaaphal	Annonaceae	Fruit
10	<i>Lagerstroemia speciosa</i> Deepu & Pandur.	Nandi mara	Lytharaceae	Flowering
11	<i>Hardwickia binata</i> Roxb.	Kamara	Fabaceae	Edible
12	<i>Neolamarckia cadamba</i> (Roxb.) Bosser	Kaduavalatige	Rubiaceae	Broad Leaf
13	<i>Dalbergia sissoo</i> Roxb.	Beete	Fabaceae	Shade
14	<i>Pithecellobium dulce</i> (Roxb.) Benth.	Seeme hunase	Fabaceae	Fruit
15	<i>Pongamia pinnata</i> (L.) Pierre	Honge mara	Fabaceae	Shade
16	<i>Tectona grandis</i> L.f.	Tega	Verbenaceae	Timber
17	<i>Mangifera indica</i> L.	Mavu	Anacardiaceae	Fruit
18	<i>Syzygium cumini</i> (L.) Skeels.	Nerale	Myrtaceae	Fruit
19	<i>Artocarpus heterophyllus</i> Lam.	Halasu	Moraceae	Fruit
20	<i>Bambusa bambos</i> (L.) Voss.	Biduru	Poaceae	Edible
21	<i>Terminalia bellirica</i> (Gaertn.) Roxb.	Thare mara	Combretaceae	Fruit
22	<i>Mallotus philippensis</i> (Lam.) Müll.Arg.	Kunkuma mara	Euphorbiaceae	Shade
23	<i>Bridelia retusa</i> (L.) A.Juss	Mullu Honne	Phyllanthaceae	Fruit
24	<i>Bauhinia purpurea</i> L.	Basavana pada	Magnoliaceae	Flower
<b>B. Plantation at Single lane (overpass) bridges</b>				
1	<i>Asparagus racemosus</i> Willd.	Shatawari	Asparagaceae	Edible
2	<i>Phyllanthus emblica</i> L.	Bettada Nelli	Phyllanthaceae	Fruit
3	<i>Wrightia tinctoria</i> (Roxb.) R.Br.	Hale mara	Apocynaceae	Edible
4	<i>Cymbopogon flexuosus</i> (Nees ex Steud.) W.Watson	Lemon Grass	Poaceae	Edible
5	<i>Vitex alata</i> Willd.	Naviladi	Lamiaceae	Shade
6	<i>Rauwolfia serpentina</i> (L.) Benth. ex Kurz	Sarphagandha	Apocynaceae	Medicinal
7	<i>Cassia fistula</i> L.	Kakke mara	Fabaceae	Edible
8	<i>Erythroxylum monogynum</i> Roxb.	Jeevadaali	Erythroxylaceae	Edible
9	<i>Gardenia gummifera</i> L.F.	Bikkegidha	Rubiaceae	Edible
10	<i>Zizyphus mauritiana</i> LAM.	Bore hannu	Rhamnaceae	Fruit
11	<i>Dodonaea viscosa</i> Jacq.	Barlu	Sapindaceae	Edible

12	<i>Dendrocalamus strictus</i> NEES	Bidiru	Poaceae	Edible
13	<i>Catharanthus roseus</i> (L.) G.DON	Nithya Pushpa	Apocynaceae	Medicinal

### 6.5 Provision of animal guides

The possibility of wild animals drown into the canal is expected and to avoid the same and rescue the wild animals, provision for animal guides (25 Nos.) at every 300 m will be provided for the entire length of the canal. "An animal guide is a combination of two pillar posts at a certain longitudinal distance on the opposite bed ends of canal joined by steel chains that helps guide the drowning animals towards a bank and saves life. Such animal Guides should have alternately opposite layout configuration (Govt. of Nepal, 2011)". This experiment was successfully implemented in Rani Jamara Kulariya Irrigation Scheme - Phase I, Nepal. Typical design and view of the animal guide is given below;

### 6.6 Provision of ramps

Whenever the wild animals fall into the canal, it is proposed to construct ramps with rough surface of 5 m at every 300 m. This will enable the animals to easy access the ground immediately. About 25 ramps are proposed.



Figure 5: Typical view of ramps

### 6.7 Impact monitoring

Changes in movement of wild animals shall be closely observed by monitoring the movement by establishing a separate monitoring wing at Kaniverampura village. This wing also acts as wildlife rescue team if necessary. The success of the proposed mitigation measures depends on how well the implementing staff has been trained on wildlife aspects

by subject experts. Hence, adequate training will be provided to the staff working at ground level.

## 6.8 Compensatory afforestation

The most significant impact that will arise due to the project includes loss of habitats due to establishment of the proposed canal and temporary access roads. As part of compensatory afforestation for the proposed diversion, 364.50 ha of non-forest land had been identified for raising Compensatory Afforestation (CA) in Sy.No 343 of Varavu Kaval village, Nayakanahatti Hobli, Chalkere Tq, Chitradurga District and transferred to Karnataka Forest Department. The CA land suitability certificate and RTC mutation copy are enclosed as Annexure V. The details of the utilization of the compensatory afforestation land for Upper Bhadra Project Package I&II are as given below;

Table 6 : Details of Forest land required and CA land provided to Karnataka Forest Department

Sl.No	Project Components	Forest land Utilization (Ha)	Stage-I Forest Clearance Reference No.	CA Land provided in (Ha)
1	Package – I (Canal from Tunga River to Bhadra Reservoir)	96.95	F.No.4-KRA 1037/2014-BAN/8002 Dt: 11.02.2016	96.95
2.	Package – II (Canal from Bhadra Reservoir to Ajjampura Tunnel)	110.10	F.No.4-KRA 1036/2014-BAN/7710 Dt: 12.11.2015	110.10
3.	Construction of Chitradurga Branch Canal	91.89	F.No.4-KRA 1035/2014-BAN/8084 Dt: 04.03.2016	111.57
<b>Total</b>		<b>298.94</b>		<b>318.62</b>

Table 7: Additional Forest Land Required for construction of Tumkur Branch Canal

Sl.No.	Name of the project component	Chainage (km)	Name of the RF	Name of the Taluk and District	Forest Land required in (Ha)
1	Tumkur Branch Canal	65.479 to 66.423	Udugere RF	Kadur Taluk of Chikmagalur district	9.28 Ha
2		150.735 to 158.357	Bukkapattana RF	Sira taluk of Tumkur District.	51.72 Ha
<b>Total</b>					<b>61 Ha</b>

Table 8 : Compensatory Afforestation Land utilization

<b>Sl.No</b>	<b>Name of the Project Component</b>	<b>Forest Land utilized/Required Ha</b>		<b>CA Land Provided in Ha</b>
1	Package I, II and III of Upper Bhadra Project	298.94	359.94	364.50
2	Construction of proposed Tumkur Branch Canal	60.10		
<b>Balance CA Land</b>				<b>4.56</b>

Once the project activities are completed, degraded areas along the canal could be restored by carrying out a reforestation/ restoration programmes. Trees can be planted along the access roads and across the canal.

Detailed cost estimates and designs of these structures will be finalized after due consultation Forest Department and for providing site specific activity plan. However, based on the initial studies, a total of Rs. Twenty-Six Crores Twenty-Two Lakhs is earmarked for implementation of wildlife management plan. The abstract showing the cost estimates for different components and along with detailed estimates are given below;

Table 9 : Cost estimate for implementation of Wildlife Management & mitigation Plan

Sl. No.	Proposed Structure	Criteria	No. of proposed structures for canal of 7547 m length	Cost per structure (Rs./-)	Total Cost (Rs./-)
1	Single lane (Over pass) bridges	One for every 1500 m	5 Nos.	1,00,00,000/-	5,00,00,000/-
2	Under passes/ culverts	One for every 150 m	50 Nos.	33,00,000/-	16,50,00,000/-
3	Super passages	One for every 1500 m	5 Nos.	63,00,000/-	3,15,00,000/-
4	Foot bridges	One for every 1500 m	5 Nos.	10,00,000/-	50,00,000/-
5	Water holes	One for every 500 m	15 Nos.	1,00,000/-	15,00,000/-
6	Animal Guide	One for every 300 m	25 Nos.	50,000/-	12,50,000/-
7	Ramps	One for every 300 m	25 Nos.	3,00,000/-	75,00,000/-
8	Chain link mesh on either sides of canal	CH.153.785 to 156.875 Km near NH-234	For 4.5 Km	1,00,000/-	4,50,000/-
9	Canal bank plantations	All along canal banks	6000 saplings (Rs. 250/- per sapling)	15,00,000/-	1,12,50,000/-
10	Maintenance of canal bank plantation for 3 years	-	-	-	25,92,000/-
<b>Total Estimated Cost (Rs./-)</b>					<b>27,60,42,000/-</b>

(In words: Twenty Seven Crores Sixty Lakhs Forty Two Thousand only)

- Bank, F. G.; C. L. Irwin, G. L. Evink, M. E. Gray, S. Hagood, J. R. Kinar, A. Levy, D. Paulson, B. Ruediger, R. M. Sauvajot, D. J. Scott, and P. White (2002). Wildlife habitat connectivity across European highways (Report). U. S. Department of Transportation: Federal Highway Administration. p. 1-45. Retrieved 19 July 2012.
- Barnum, S.A (2003), Identifying the best locations along highways to provide safe crossing opportunities or wildlife: a handbook for highway planners and designers. Colorado Department of Transportation.
- Bhaskar, V. & Kushalappa, C. G. (2017). Flora of Tumkur District Karnataka. Centre for Plant Taxonomic Studies, Bangalore. P.1-284.
- Bhaskaran N. and Sukumar, R. (2011). Karnataka Elephant Census; Technical report to the Karnataka Forest Department – 2010. Asian Nature Conservation Foundation and Centre for Ecological Sciences, Indian Institute of Science, Bangalore - 560 012, Karnataka.
- Cain, A.T., V.R. Tuovila, D.G. Hewitt, and M.E. Tewes (2003), Effects of a highway and mitigation projects on bobcats in Southern Texas. *Biological Conservation* 114: 189-197.
- Clevenger, A. P., and J. Wierzchowski. (2006). Maintaining and Restoring Connectivity in Landscapes Fragmented by Roads. In K.R. Crooks and M. Sanjayan (Eds.), *Maintaining Connections for Nature*, Cambridge University Press: 502-35.
- Clevenger, A.P., and N. Waltho (2005), Performance indices to identify attributes of highway crossing structures facilitating movement of large mammals. *Biological Conservation* 121: 453-464.
- Clevenger, A.P., B. Chruszcz, and K. Gunson (2001), Drainage culverts as habitat linkages and factors affecting passage by mammals. *Journal of Applied Ecology* 38: 1340-1349.

- Environmental Impact Assessment Report of Modifications to Configurations of Moragahakanda-Kaluganga Projects (2014). Ministry of Irrigation & Water Resources, Govt. of Srilanka.
- Environmental Management Plan - Final Report of Modernization of Rani Jamara Kulariya Irrigation Scheme Phase - I (2011). Ministry of Irrigation, Nepal
- Evink, G.L (2002), Interaction between roadways and wildlife ecology. National Academy Press, Washington, D.C.
- <http://environment.fhwa.dot.gov/ecosystems/wvc/ch4.asp>
- <http://environment.fhwa.dot.gov/ecosystems/wvc/ch4.asp>
- [http://environmentclearance.nic.in/writereaddata/Online/TOR/0\\_0\\_17\\_Mar\\_2015\\_1701254401ProposedToR.pdf](http://environmentclearance.nic.in/writereaddata/Online/TOR/0_0_17_Mar_2015_1701254401ProposedToR.pdf)
- <http://tricitycountryproperty.com/category/buyer-tips/>
- <http://www.aboutcivil.org/cross-drainage-works.html>
- <http://www.conservationindia.org/news/conservationists-win-legal-battles-in-bhadra-tiger-reserve>
- <http://www.glogster.com/mcqgeography/2122156-so/g-6jqntf30qod33pj3651272f>
- [http://www.indianetzone.com/71/shettihalli\\_wildlife\\_sanctuary.htm](http://www.indianetzone.com/71/shettihalli_wildlife_sanctuary.htm)
- [http://www.johnweeks.com/river\\_mississippi/pages01/larsonculvert.html](http://www.johnweeks.com/river_mississippi/pages01/larsonculvert.html)
- <http://www.sanctuariesindia.com/animals/animal-sanctuaries-in-karnataka/>
- <http://www.theguardian.com/travel/2013/dec/05/guide-to-indias-tiger-reserves-conservation>
- [https://www.bchydro.com/bcrp/projects/docs/bridge\\_river/01W08.pdf](https://www.bchydro.com/bcrp/projects/docs/bridge_river/01W08.pdf)
- <https://www.iucnredlist.org/>
- Jareemiah Pate Purdam (2013). Acceptance of Wildlife Crossing Structures on US Highway 93, Missoula, Montana, University of Montana, Missoula, US
- Jhala Y.V., Qureshi Q., Gopal R., and Sinha P.R. (eds) 2015. The status of tigers in India 2014. National Tiger Conservation Authority, New Delhi & The Wildlife Institute of India, Dehradun.

- Jhala Y.V., Qureshi Q., Gopal R., and Sinha P.R. (Eds.) 2011. Status of the Tigers, Co-predators, and Prey in India, 2010. National Tiger Conservation Authority, Govt. of India, New Delhi, and Wildlife Institute of India, Dehradun. TR 2011/003 pp-302
- Jochen A.G. Jaeger, Jeff Bowman, Julie Brennan, Lenore Fahrig, Dan Bert, Julie Bouchard, Neil Charbonneau, Karin Frank, Bernd Gruber, Katharina Tluk von Toschanowitz (2005), Predicting when animal populations are at risk from roads: an interactive model of road avoidance behavior, *Ecological Modeling*, 185: 325-348.
- Joe Materi, R.P.Bio., Charlene Forrest, M.Sc., Salmon River Diversion Wildlife overpass Pilot Project, Final report, November 30, 2014,
- Kunwar, A., R. Gaire, K.P. Pokharel, S. Baral & T.B. Thapa (2016). Diet of the Four-horned Antelope *Tetracerus quadricornis* (De Blainville, 1816) in the Churia Hills of Nepal. *Journal of Threatened Taxa* 8(5): 8745-8755; <http://dx.doi.org/10.11609/jott.1818.8.5.8745-8755>.
- Little, S.J. (2003), The influence of predator-prey relationships on wildlife passage evaluation. *ICOET*, 2003.
- Mata, C., I. Hervas, J. Herranz, F. Suarez, and J.E. Malo (2005), Complementary use by vertebrates of crossing structures along a fences Spanish motorway. *Biological Conservation* 124: 397-405.
- McDonald, W., and C.C. St Clair (2004), Elements that promote highway crossing structure use by small mammals in Banff National Park. *Journal of Applied Ecology* 41: 82-93.
- Mishra S. K. and Mohanty S. K, Site Specific Conservation Plan for Thermal Power Plant in Naraj of Cuttack District, Orissa, Tata Power Company Ltd.
- Narendra Prasad S., Vijayakumaran Nair P., Sharatchandra H C. and Madav Gadgil (1978). Distribution of Wild Mammals in Karnataka, *Journal of Bombay Natural History Society*, Vol. 75, Pg 718-743
- Ng, S.J., J.W. Dole, R.M. Sauvajot, S.P.D. Riley, and T.J. Valone (2004), Use of highway under crossings by wildlife in southern California. *Biological Conservation* 115:499-507.

- Paul Beier, Dan Majka, Shawn Newell, Emily Garding (2008), Northern Arizona University, US
- Paul Beier, Dan Majka, Shawn Newell, Emily Garding, Northern Arizona University January 2008 Best Management Practices for Wildlife Corridors (Page 3 to Page 4)
- Revised Management Plan for Kudremukh National Park (2003). Deputy Conservator of Forests, Kudremukh Wildlife Division, Karkala, Karnataka Forest Department.
- Revised Management Plan for Upper Bhadra Lift Irrigation Scheme (Packagae I&II) (2016). Karnataka Forest Department, GoK.
- Ruediger, B. (2001), High, wide, and handsome: designing more effective wildlife and fish crossings for roads and highways. ICOET 2001.
- Salmon River Diversion Wildlife Overpass Pilot Project (2004), Joe Materi R.P.Bio, Charlene Forrest, Columbia.
- Species and planting technique models, General Guidelines by Karnataka Forest department. <https://aranya.gov.in/downloads/Planting-Techniques.pdf>
- Srivastava D.S., Easa P.S and Jauher J. B. (2013). Integrated Wildlife Management Plan for West Singhbhum, Jharkhand; Report submitted to Dept., of Forest and Environment, Govt. of Jharkhand.
- Sukumar, R. (1986). The elephant populations of India - Strategies for conservation, Proceedings of Indian Academy of Sciences (Animal Science /Plant Science), Supplementary, Pg. 59-71.
- Varma, S. and Sukumar, R. (2012). Synchronized Population Estimation of the Asian Elephant in Forest Divisions of Karnataka -2012; Final report submitted to Karnataka Forest Department – December 2012. Asian Nature Conservation Foundation and Centre for Ecological Sciences, Indian Institute of Science, Bangalore - 560 012, Karnataka.
- Wilcove DS, McLellan CH, Dobson AP. 1986. Habitat fragmentation in the temperate zone. In Conservation Biology, ed. ME Soul6, pp. 237-56. Sunderland, MA: Sinauer.
- Wildlife crossings - Wild animals and roads, The Humane Society of the United States. Archived from the original on 27 September 2007.

- Wildlife Management Plan for Bhadra Wildlife Sanctuary (2005). Deputy Conservator of Forests, Bhadra Wildlife Division, Chickmagalur, Karnataka Forest Department.
- Wildlife Management Plan for Mookambika Wildlife Sanctuary (2010). Deputy Conservator of Forests, Kudremukh Wildlife Division, Karkala, Karnataka Forest Department.
- Wildlife Management Plan for Someshwara Wildlife Sanctuary (2003). Deputy Conservator of Forests, Kudremukh Wildlife Division, Karkala, Karnataka Forest Department.
- Wildlife Management Plan for Someshwara Wildlife Sanctuary (2005). Deputy Conservator of Forests, Wildlife Division, Shimoga, Karnataka Forest Department.
- Working Plan for Tumkur Forest Division (2015). Conservator of Forests & Deputy Conservator of Forests, Working Plan & Survey, Chikmagalur, Karnataka Forest Department.