

AREA DETAIL :-
 TOTAL PLOT AREA = 1916.99 SQ.M.
 Khazra No. = 30/1/6/2/2
 Village = ZARDARPUR
 Police Station = Bahadurgarh
 Railway Station = BAHADURGARH
 POST OFFICE = Bahari
 Tehsil = Bahajpur
 District = Haryana (124508)
 State = Haryana

- NOTES:-**
1. Certified that there is no other structure will be erected nor any other service rendered except that connected with the petrol pump without the prior approval of P.W.D.
 2. Certified that there is no objection from road point of view for the installation of this pump.
 3. The proposal will not effect the future improvement of the road.
 4. Certified that the berm portion is not included in the area of land to be leased from P.W.D. for approach road but is to be metalled by the corporation.
 5. Certified that all the conditions laid down by the Govt. of India and irc from time to time with regard to the location of road side fuel-filling cum service stations have been complied with entire construction will be on corporation land.
 6. No drain, sewer or structure within 1.5m from under ground tank.
 7. Suction pipes, under drive-way housed in pipe sleeves.
 8. Electric fitting conform to ISS code no 2148 for dispensing pumps only.
 9. D.P.S. board 1.50m high from floor level and will not be kept under lock and key.
 10. Tanks fed by tank lorry.
 11. No hedges and plants more than .60m high should be grown around the buffer strip.
 12. There should be sufficient standing space inside the station for vehicles to wait for their turn.
 13. In & Out signing are put up to guide vehicles during the day and one at proper ht. to guide at night.
 14. All the structure (if any on Govt. land) should be provided.
 15. No smoking sign, fire extinguisher and fire buckets provided at site.
 16. 50 mm Vent pipes, 4m high from ground level and 4m clear around. The open end of Vent pipes covered with two layers of non corrodible metal wire gauge of 11mesh per linear cm.
 17. Certified that buffer should not have any installation i.e. under ground tanks etc.
 18. Certified that the kerbing along buffer is to be made by corporation.
 19. Certified that the metalling of the berm at the cost of company is to be provided.
 20. Certified that there will not be any hindrances from over head lines & poles.
 21. Certified that the surplus water will not be disposed off in P.W.D. land.
 22. Certified that all clearances/approvals from most irc and other relevant Govt. departments shall be obtained before commencement of work.
 23. Certified that there is no court case pending in any court of india against this premises and dealership.

PRODUCT	CAPACITY	NO OF TANK	PUMP NO OF NOZZLES	CAPACITY (L)	(D)	P11	P12
ISKL	20KL	1NO	4NOS	20KL	2.01MØ	6MM	8MM
MIS	1SKL	1NO	4NOS	1SKL	2.01MØ	6MM	8MM

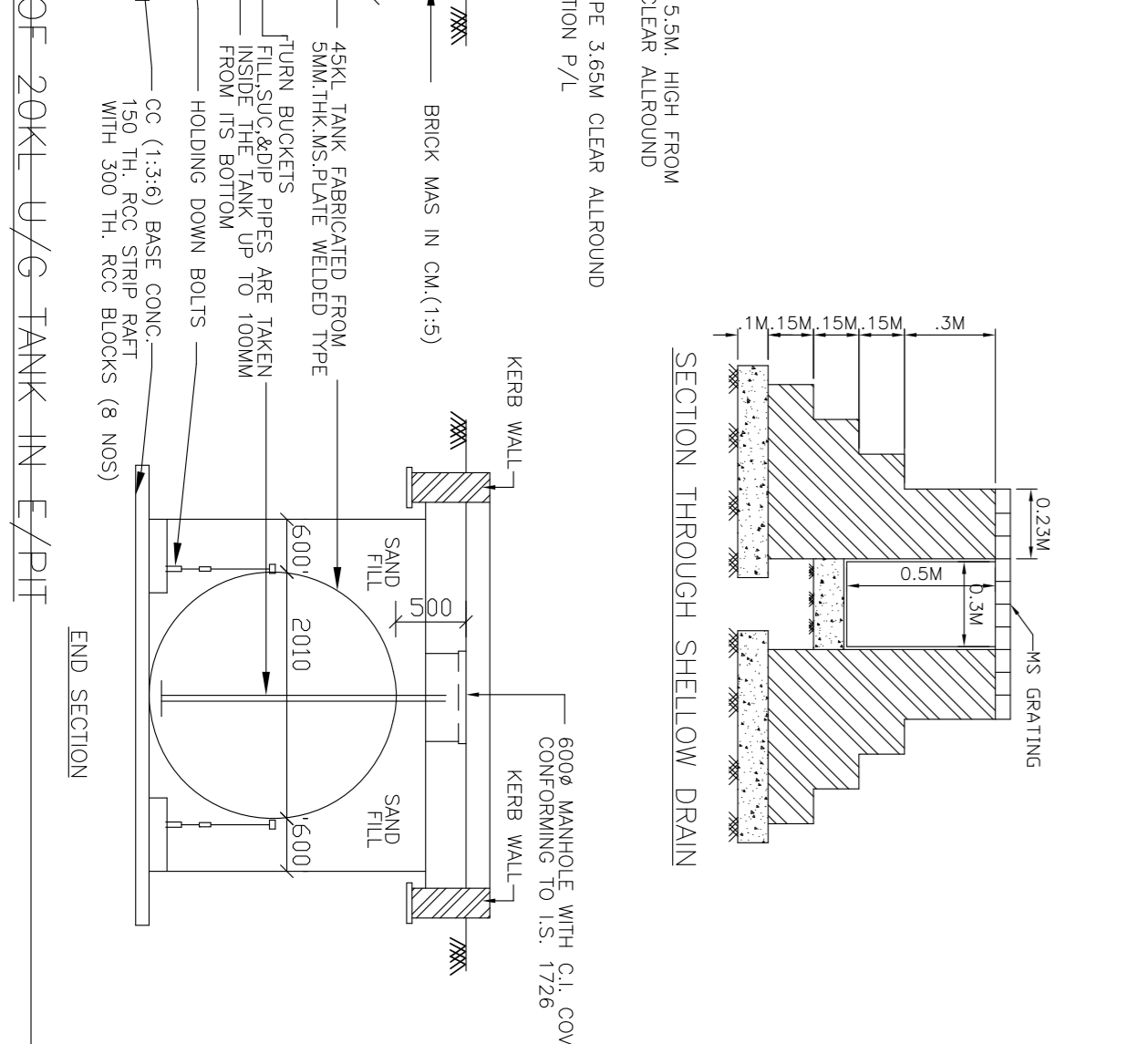
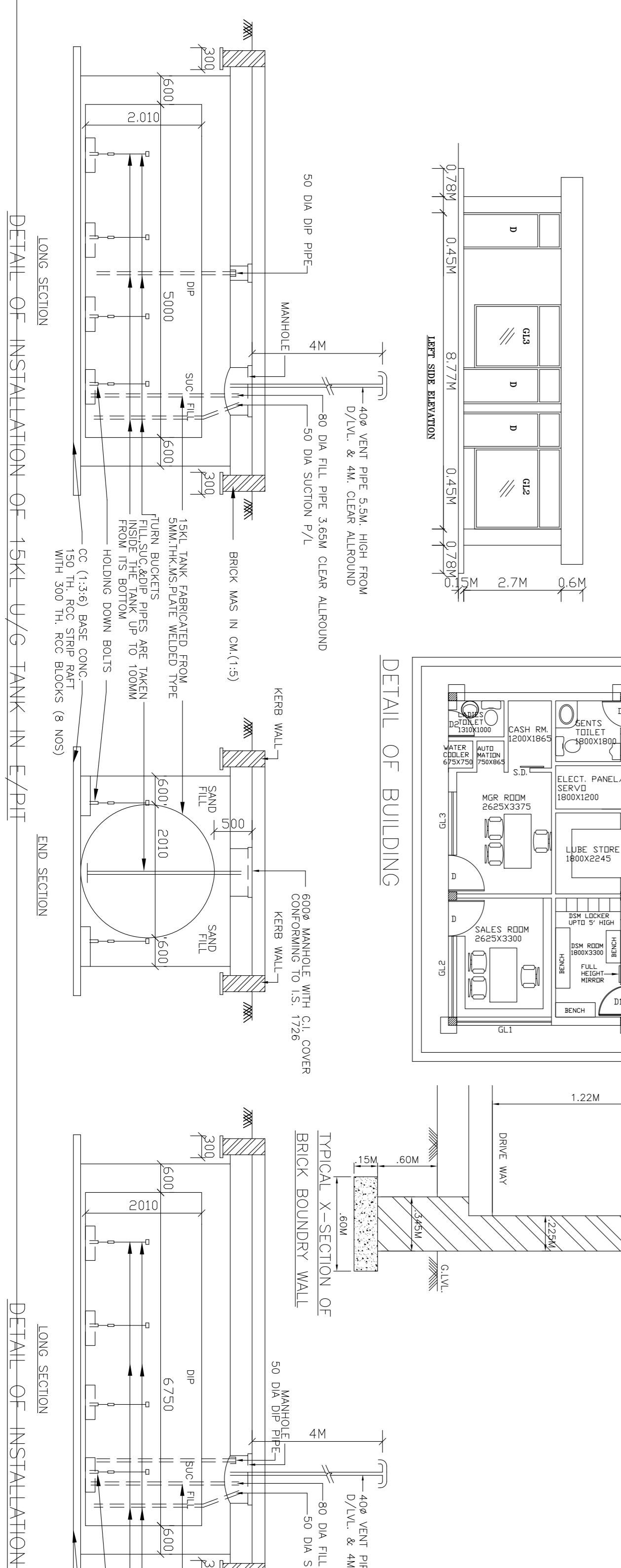
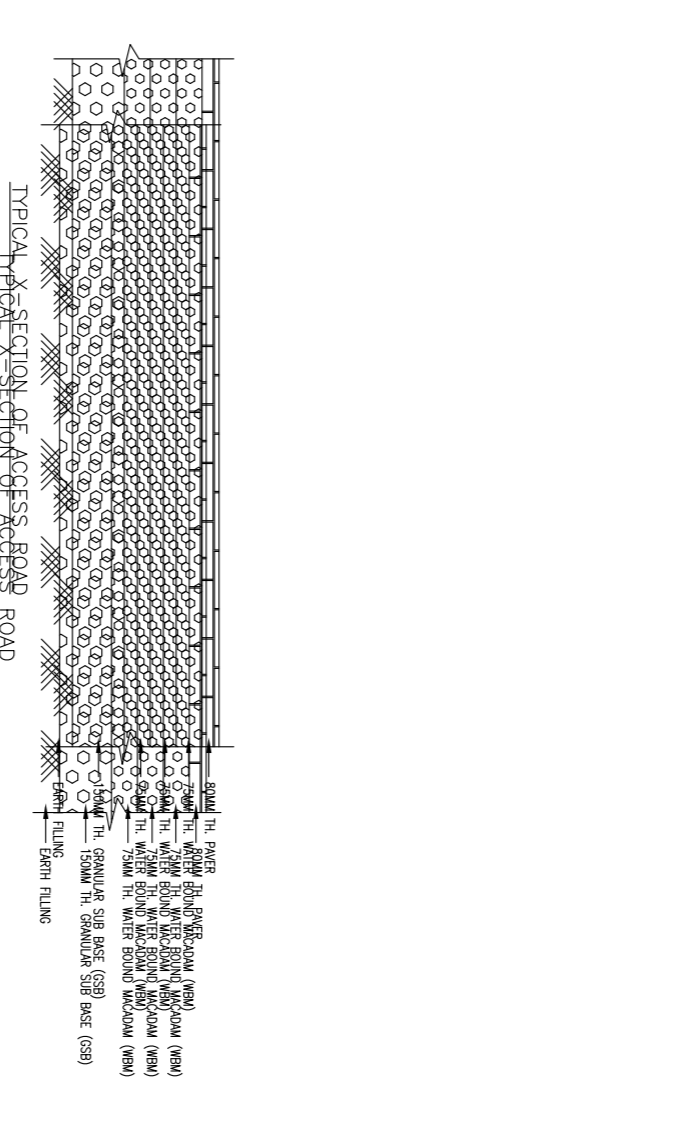

BRHARAT PETROLEUM CORPORATION LIMITED

SITE AND LAYOUT PLAN OF RETAIL OUTLET AT VILLAGE ZARDARPUR ON BAHADURGARH BAPU ROAD (RHS), TEHSIL BERI DISTT. JHAJJAR(HARYANA) PIN CODE - 124508

DRAWN: KUMAR
 CHKD
 APPRD

PREPARED BY: TECHNICAL ENGINEERS NEW DELHI
 MOBILE NO. 09598913456

DATE : 09.09.2016
 SCALE : 1:150

DRG. NO. BPC/ZARDARPUR/09092019

NUMBERS CROSSED OUT ARE SUPERSEDED DRAWING NO.

LICENCE NO New