

**Himani Chamunda Passenger Ropeway
MUCK MANAGEMENT PLAN (MNP)**

Sr.	Description	Quantity
1	Total Quantity of Muck being produced	6500
2	Deduction for useful stone as required under thw clause of agreement to be excuted by the Contractor and Execuitive Engineer of Project.	Nil
3	Net Balance Quantity of Debries/Muck (1-2)	6500
4	Quantity available on site with swell factor @ 40% 1.40A	2600
	Total (sr.3+4)	9100cum(B)
5	Material /Muck to be used in Project:-	
(i)	Deduction of material required for the construction of dumping place in dry masonry wall/Edge wall @ 15% of (B)	1365
(ii)	Less for material/Muck required for leveling of the proposed site for the construction of tower & station @25% of (B)	2275
	Total :- (i)+(ii)	3640(C)
6	Net material/Muck to dumped in dumping site (B-C) in Cum	5460

Total Capacity of Dumping Site on project :- 5700

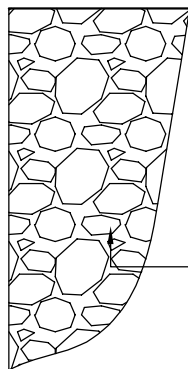
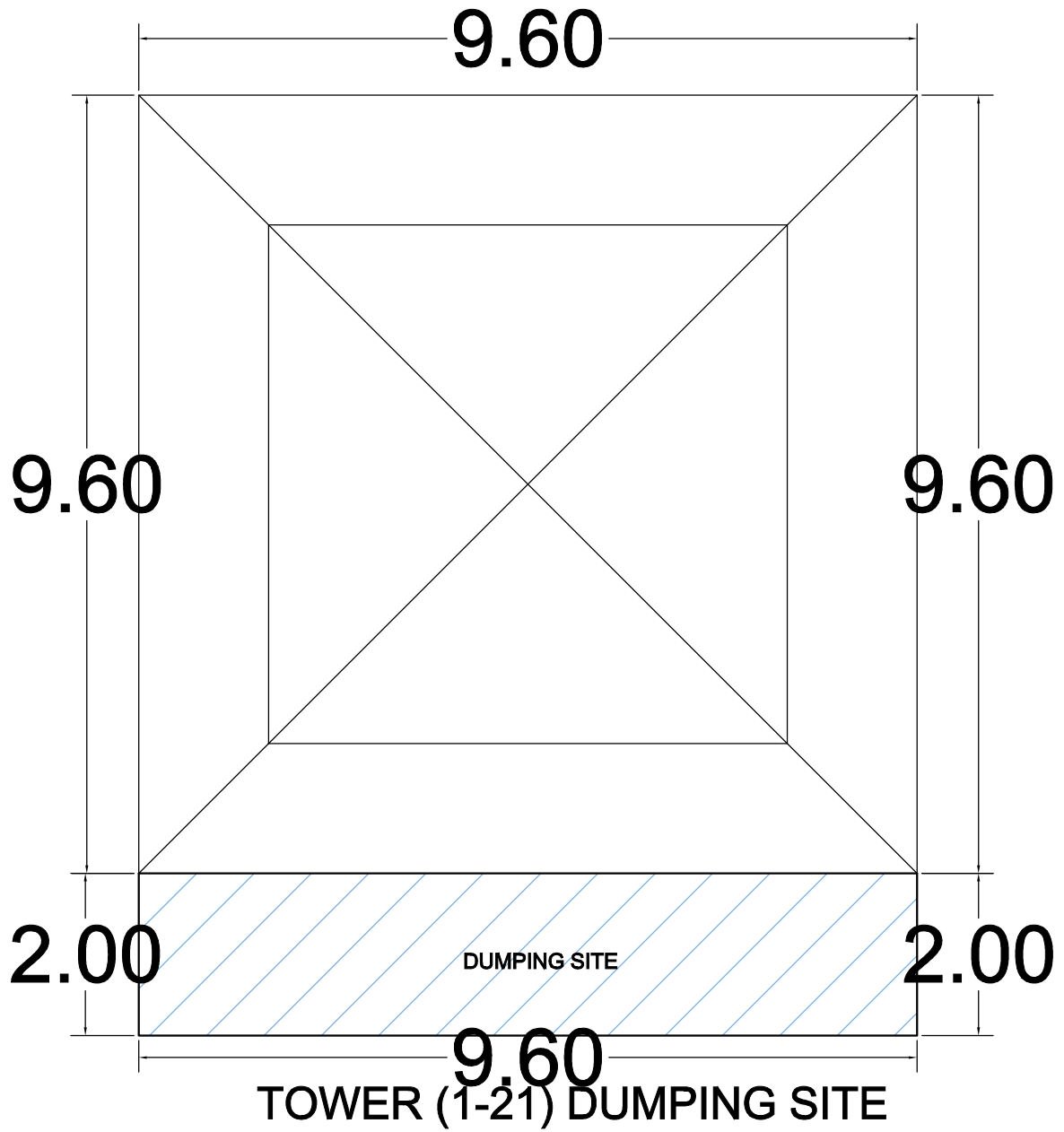

 Deputy Director (Tourism)
 Distt. Tourism Dev. Office
 Kangra at Dharamshala
 ☎ : 01892 - 224430

PROPOSED HIMANI CHAMUNDA PASSANGER ROPWAY

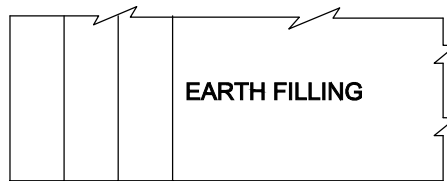

EARTH FILLING

4.00m



9.60m

TOTAL DUMPING=	L	W	H	NO.S	QNTY
DUMPING SITE =	9.60	2.00	4.00	21	= 1612.80 CUM

Deputy District Commissioner
Distt. Tourism Dev. Office
Kangra at Dharamshala
☎ : 01892 - 224430

WIRE CREATE TOWER (1-21)

VASTUKAR & ASSOCIATES
ARCHITECTS ENGINEERS ESTIMATORS
LANDSCAPERS INTERIOR DESIGNER
PAINTERS & POLISH TEAM

PROPOSED HIMANI CHAMUNDA PASSANGER ROPWAY

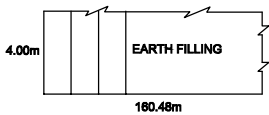
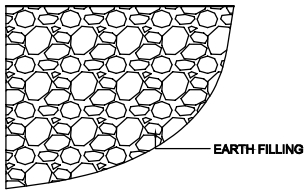
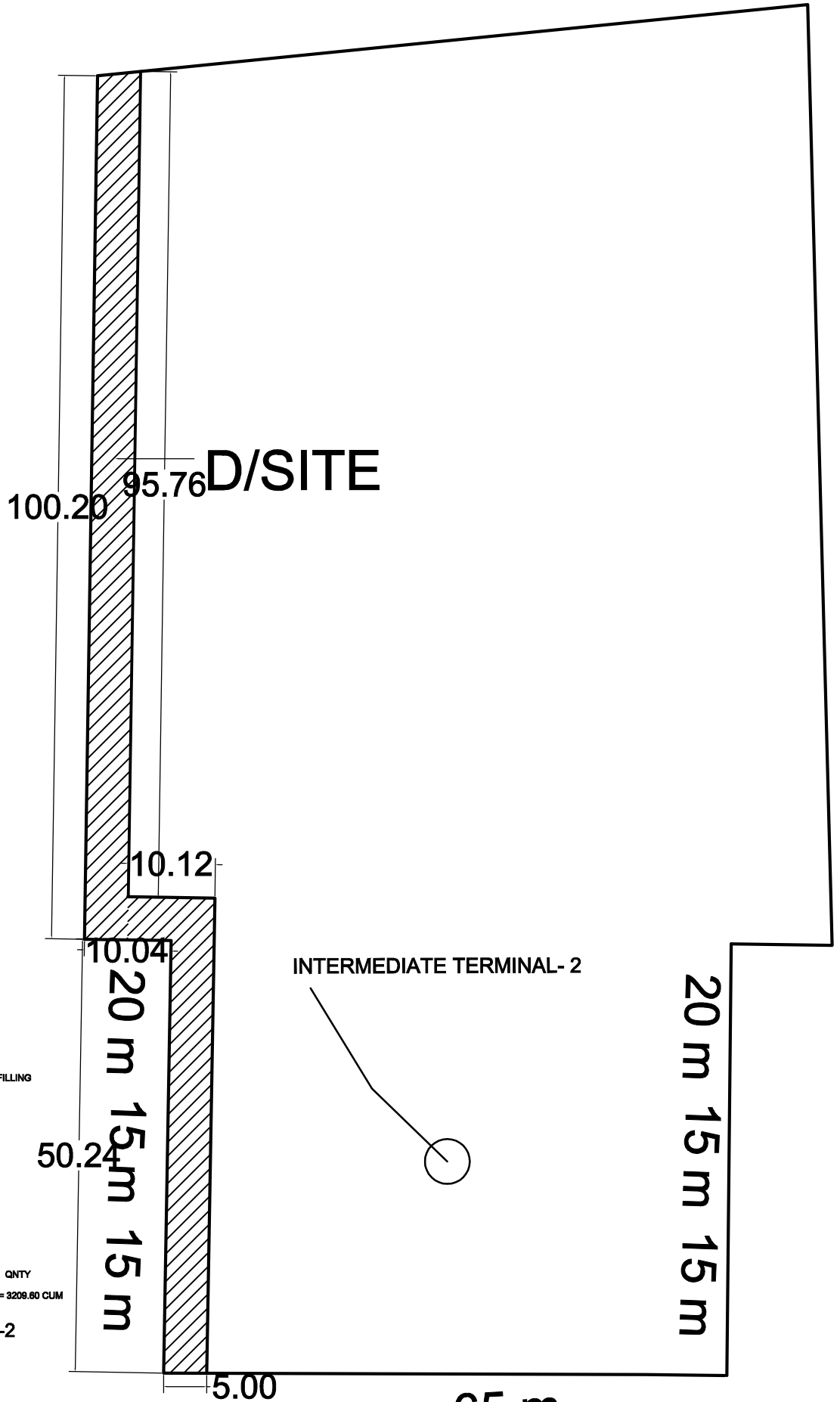

TOTAL DUMPING=	L	W	H	NO.S	QNTY
DUMPING SITE =	180.48	5.00	4.00	1	= 3209.80 CUM

WIRE CREATE TERMINAL-2



 Deputy District Commissioner
 Distt. Tourism Dev. Office
 Kangra at Dharamshala
 ☎ : 01892 - 224430

65 m
TERMINAL-2 DUMPING SITE

VASTUKAR & ASSOCIATES
 ARCHITECTS ENGINEERS ESTIMATORS
 LANDSCAPERS INTERIOR DESIGNER
 CONTRACTOR & CONSULTANTS

PROPOSED HIMANI CHAMUNDA PASSANGER ROPWAY

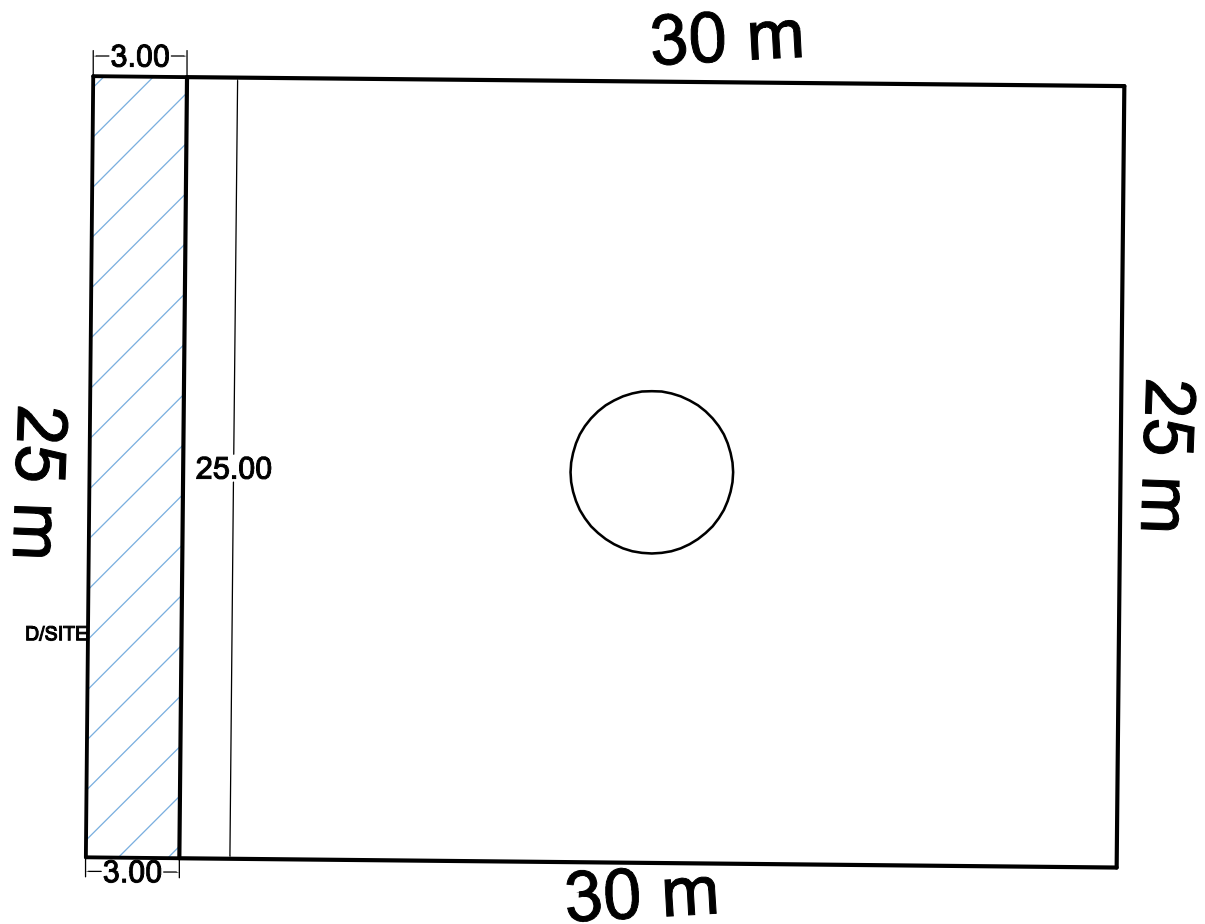
UPPER STATION TERMINAL- 3



TERMINAL- 3 DUMPING SITE

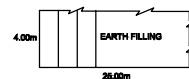
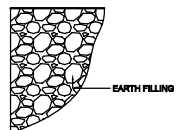

TOTAL DUMPING	L	W	H	NO.S	QNTY
DUMPING SITE	= 25.00	8.00	4.00	1	= 300.00 CUM

WIRE CREATE TERMINAL-3

Deputy District Engineer
Distt. Tourism Dev. Office
Kangra at Dharamshala
☎ : 01892 - 224430

VASTUKAR & ASSOCIATES
ARCHITECTS ENGINEERS ESTIMATORS
LANDSCAPERS INTERIOR DESIGNER
CONTRACTOR & CONSULTANTS